



CUCINA GAS CON PILOTA SU FORNO STATICO GAS 1/1



GAS RANGE WITH PILOT ON 1/1 STATIC GAS OVEN



M74FPFXG/M74FMPFXG



M76FPFXG/M76FMPFXG



DESCRIZIONE PRODOTTO / PRODUCT DESCRIPTION

Piano di cottura a gas forno statico gas. Piano stampato spessore 10/10. Bruciatori costruiti in ghisa nichelata, completi di fiamma pilota. I fuochi sono comandati da rubinetti di sicurezza con termocoppia e regolazione progressiva della potenza erogata. Forno statico gas con dimensioni Gastronorm 1/1, riscaldato da un bruciatore in tubolare d'acciaio con accensione piezoelettrica. Controllo della temperatura ottenuta per mezzo di un rubinetto termostatico di sicurezza con termocoppia. Griglie superiori in ghisa vetrificata. Struttura costruita in acciaio inox.

Gas boiling unit on static gas oven. Pressed cooking top thickness 10/10. Burners made in cast iron nickel-plated, with pilot flame. Burners are controlled by safety taps with thermocouple and gradual regulation of the power supplied. Static gas oven with Gastronorm dimensions 1/1, heated by a stainless steel tubular burner with piezoelectric ignition. Temperature control made by safety tap with thermocouple. Upper grids in cast iron vitrified. Framework made in stainless steel.

CARATTERISTICHE TECNICHE

TECHNICAL CHARACTERISTICS

	M74FPFXG/M74FMPFXG	M76FPFXG/M76FMPFXG
Dimensioni / Dimensions	800 x 700 x 900 mm	1000 x 700 x 900 mm
Peso netto / Net weight	89 Kg	105 Kg
Altezza regolazione piedini Ø 1"1/2 / Height adjustment of feet Ø 1"1/2	120/160 mm	120/160 mm
Riciclabilità % del peso apparecchio / Recyclability % weight of appliance	98%	98%
Pressione gas / Gas pressure	mbar	mbar
Tipo gas G20-G25* / Type of gas G20-G25*	20/25	20/25
Opzione gas G30-G31* / Gas option G30-G31*	28...30/37	28...30/37
Ø entrata gas / Gas inlet Ø	1/2"	1/2"
Potenza totale gas / Gas total power	27,6 kW / 23,6 kW	39,6 kW / 33,6 kW
Consumo G20 20 mbar / Consumption G20 20 mbar	2,921 m ³ /h / 2,497 m ³ /h	4,191 m ³ /h / 3,555 m ³ /h
Indice di protezione all'acqua / Water ingress protection rating	IPX4	IPX4
Potenza forno gas / Gas oven power	3,6 kW	3,6 kW
Interno forno / Oven interior	580 x 380 x 300 mm	580 x 380 x 300 mm
Numero di livelli / No. shelf positions	4	4
Spazio tra 2 livelli / Space between 2 shelves	75 mm	75 mm
Suola forno / Oven floor	549 x 364 mm	549 x 364 mm
Dimensioni imballo / Package dimensions	815 x 750 x 1120 mm	1020 x 754 x 1120 mm
Peso lordo / Gross weight	96 Kg	113 Kg
Volume / Volume	0,68 m ³	0,86 m ³

* Secondo il paese di destinazione / According to the country of destination

EMME 7

EMME



CUCINA GAS CON PILOTA SU FORNO STATICO GAS 1/1



GAS RANGE WITH PILOT ON 1/1 STATIC GAS OVEN

M74FPFXG/M74FMPFXG

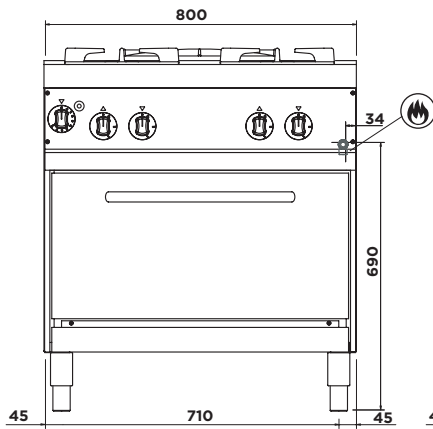

M76FPFXG/M76FMPFXG

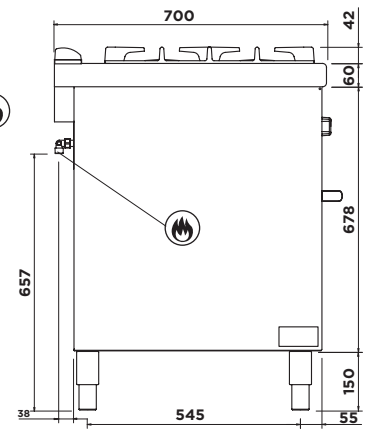
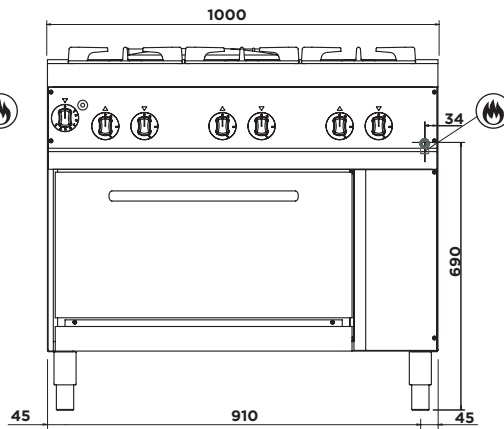

M74FPFXG

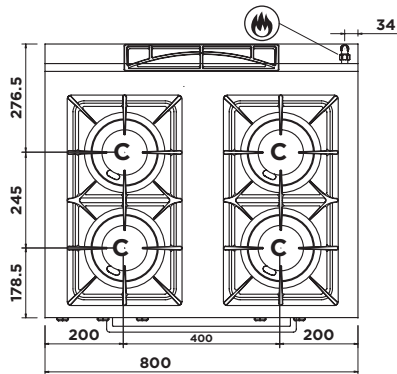

M76FPFXG

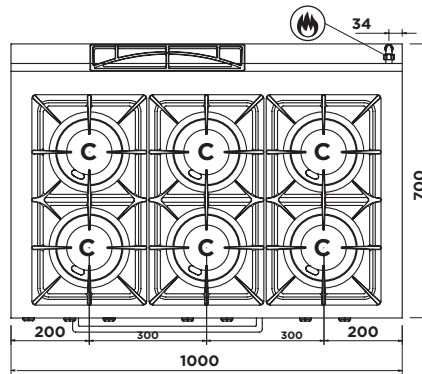

B = 4,0 kW

C = 6,0 kW

M74FMPFXG

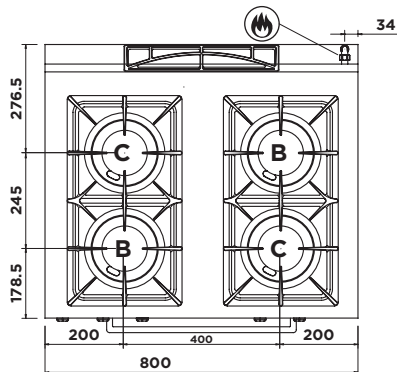

M76FMPFXG

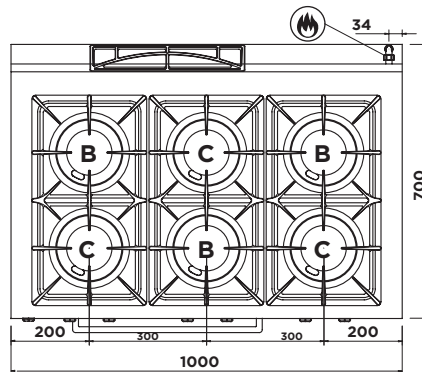

1/2" GC

MADE IN ITALY

GIGRA
GRANDI CUCINE

0114 REV 00